



Interprovincial Welder Journeyperson Certification

Practical Examination Information

This information is current as of May 14, 2024

There is a written and a practical component to the Journeyperson examination. With the exception of apprentices attending the final level of technical training, the written examination must be completed successfully before applying for the practical examination.

VISIT OUR WEB SITE!

www.saskapprenticeship.ca

Verbal abuse by candidates towards any person at the examination facility will not be tolerated. Instances of this abuse will result in the immediate termination of the candidate's examination attempt at the expense of the candidate.

All communication and/or imaging devices are prohibited from use at all times during the practical examination.

Please note that examinations and study information change frequently. The most recent information is available on our web site at www.saskapprenticeship.ca

1-877-363-0536
apprenticeship@gov.sk.ca
saskapprenticeship.ca



Please read all the information provided before you start the examination.

This examination is comprised of five welding process tests (measurement, visual and bend), one gouging test (measurement and visual) and three oxy-acetylene cutting tests (measurement and visual). Unless advised otherwise by the examining officer, you may do the tests in any logical order. Review the enclosed marking sheet for specifications.

Materials Provided:

- 9 pieces - 4 in. x 5 in. x 3/8 in. Mild Steel A-36 Plates cut at 30° both ends
- 2 pieces - 4 in. x 5 in. x 3/8 in. Mild Steel A-36 Plate cut at 90° both ends
- 1 piece - 2 in. x 7 in. x 1/4 in. Mild Steel (backing plate) cut at 90° both ends
- +/-1 in. x 2 in. Mild Steel tabs for bridge or run off tabs.
- All required welding electrodes, welding wire and shielding gas as described in the following pages
- Smaller plate pieces for setting of welding machine

Candidate to Provide:

- Helmet, goggles, gloves, personal hand tools and appropriate safety equipment including CSA approved work boots or other suitable footwear. **Candidates not having this safety equipment will not be allowed to perform the test at this time.**
- Angle grinder, grinding discs and buffing wheel

General Instructions:

1. You will be allowed five (5) hours to complete this examination. Failure to complete any welding/cutting processes within the five (5) hour time frame will result in an automatic complete fracture rating for that process. The pass mark is 70%. Do not engage in needless conversation with examiners or other candidates. Pay close attention to the availability of welding and cutting stations in order to complete the examination in the time allotted.
2. **You must follow these instructions precisely**, as well as any additional instructions by the examiners. You may ask the examiners for clarification of these instructions at any time.
3. You are required to wear and/or use all appropriate safety equipment.
4. It is the responsibility of the candidate to ensure all welding/cutting equipment is set up for the proper process.
5. **There is no extra set of coupons issued during this examination.** The original coupons issued at the beginning of the examination are the only coupons you will have to work with. Extra coupons will only be issued in the event of a retest.
6. **Plates must be stamped** with candidate number and position letter, as illustrated on the following pages, **before** beginning the exam.

7. Any **single** strap receiving a complete fracture rating will result in a retest of the failed position immediately following this examination. During the retest both straps of the coupon will be bent on the face or root as applicable. One (1) hour will be allowed for this retest. **Note: Failure to complete this retest when instructed to do so by the examiners will result in failure of the entire examination. This retest may not be done at any time other than the day of the original examination.**
8. Any **two** straps receiving a complete fracture rating will result in failure of the entire examination.
9. When you have completed the examination, clean up your workstation.
10. Tests will be marked in the absence of the candidates. Stay away from the bending station until called by the examiners to review your examination results.
11. There is no "partial" retest following the **failure** of this examination.
12. Official examination results will be posted in MyATC within 4 weeks.

Welding Process Tests

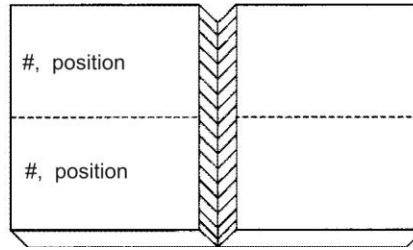

- Before beginning to weld, stamp your coupons as illustrated above with your candidate number, **leave a space**, and then the position letter. For example, if your candidate number is 3 and the coupon is for the vertical position, mark the coupon **3 V** on both halves. For project 4, the double position, use the letter **D** as the position number. **Retest coupons** (if required) are to be stamped in the same way, except **double stamp** the position letter before beginning any welding.
- Coupons are to be tacked to each other on the bevel side unless otherwise described for each project. Maximum length of tacks is 1/2 in. after feathering. All tacks and feathering of tacks may be done in the flat position. Any tool or grinder may be used for feathering of tacks. If the tack appears faulty you may remove it. Bevel face repair is limited to area of tack removal. Further bevel face repair will result in point deductions at the discretion of the examiners. The original bevel must still be used following any tack repair. Coupons **may not** be rotated. Run-off tabs and/or bridge tacks are allowed only in project #5.
- All welding is to be done from the bevel side **only**.
- **All** roots must be completed as described in the following pages. Root passes must be completed and ground **in position only**. **NOTE: For project #4 it is required to request a marker to inspect your GTAW root pass IN POSITION once it has been completed** before proceeding with the FCAW fill and cap. Once completed, a root pass can **not be removed**. In the event that the entire root pass is unable to be completed without a stoppage, a tie-in is allowed. The stop is allowed to be feathered **while in position only**. Removal of an entire root pass will result in **failure of the entire examination**.
- Fill and cover passes **may not** be ground during the welding process.
- When completed, **wire wheel or wire brush only** and present your completed coupons to the examiners for marking **before surface grinding begins**.
- Grind the welded surfaces to the thickness of the original parent metal. **Maximum** deviation is +/-1/32 in.
- **Failure to maintain original coupon thickness to within +/-1/32 in. throughout the weld area will result in a COMPLETE FRACTURE rating for the strap.**
- The excess weld metal deposited at the edges of the 5 in. coupons may be ground flush with the parent metal. **Do not grind parent metal.**

- Cut the coupons lengthways once down the middle. **Only freehand oxy-fuel torch cutting is allowed.** Outside edges may **not** be cut. Straps measuring less than 2 3/8 in. will have 2 points deducted. **Minimum width is 2 5/16 in.** Straps measuring less than this minimum will receive a **COMPLETE FRACTURE RATING.** **Do not grind the cut edges of the coupons.** **Grinding or using a straight edge on any flame-cut edge of any strap will result in a deduction of 10 points from that strap.** Knock off the slag and **lightly** file the flame-cut edges to remove any burrs.
- During bending, a **complete fracture** is a fracture exceeding 1/4 in. starting from either edge or exceeding 1/8 in. anywhere else. A **single** strap having a complete fracture will result in a **retest** of the failed position at the end of this examination. **Two** straps having a complete fracture will represent a **failure of the entire examination.** Partial fractures less than the above limitations will have 1 point deducted per 1/16 in.

Welding Processes Test

5 Projects

Project 1: Vertical Position

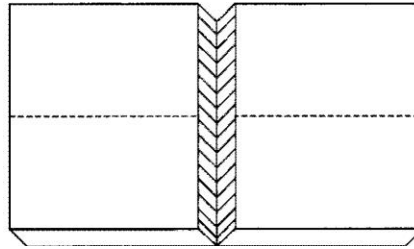

- 3/8 in. plate V-groove butt joint
- E6010 root - **uphand** - 1/8 in. electrode diameter
- E7018 fill and cap - **uphand** - electrode diameter at the discretion of the candidate
- Land and gap to be determined by candidate
- **NOTE:** coupons must be tacked **within the bevel only** using E6010

Project 2: Horizontal Position

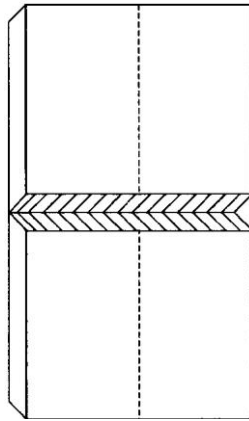

- 3/8 in. plate V-groove butt joint
- E6010 root - 1/8 in. electrode diameter
- E6010 fill and cap - 1/8 in. electrode diameter
- Land and gap to be determined by candidate
- **NOTE:** coupons must be tacked **within the bevel only** using E6010

Project 3: Overhead Position

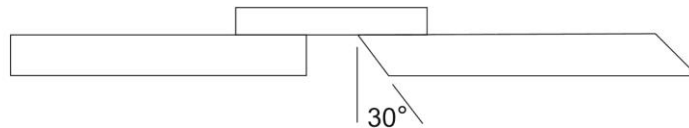
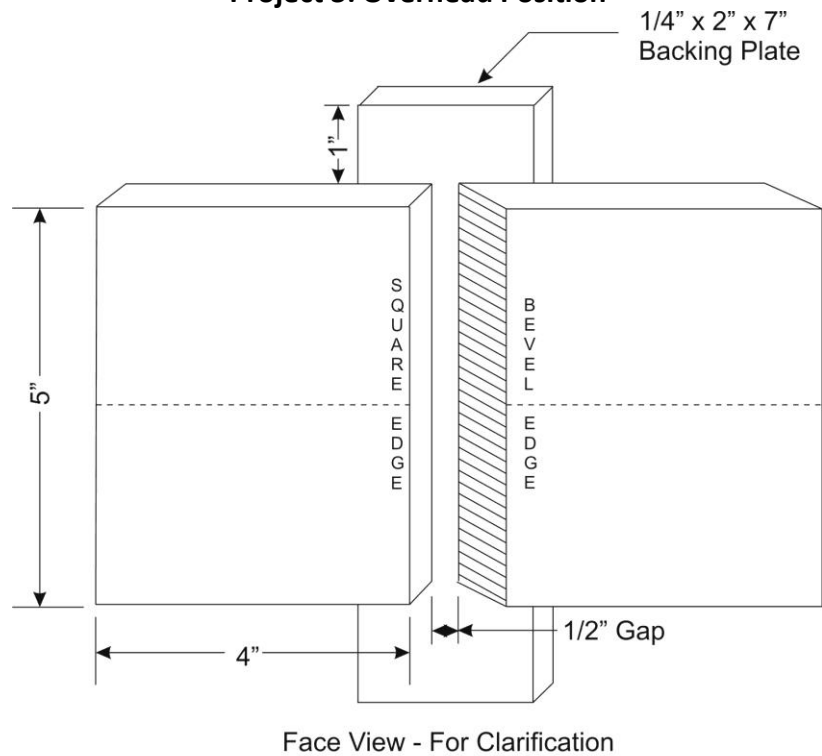

- 3/8 in. plate - 90° to 30° bevel with backing plate
- Root gap must equal 1/2 in.
- Backing plate is to be tacked on the backside of the coupons
- Coupon must be presented to the markers for verification of fit-up **prior to beginning root weld**
- Only stringer beads are allowed on this position test
- 7018 fill and cap - 1/8 in. rod diameter - **no grinding** is allowed at any time during the welding or gouging processes, wire wheel only
- Backing plate must be removed by air arc gouging to **within 1/16 in.** of the parent metal. Failure to do so will result in a deduction of up to 10 points in the "*Condition of the Gouge*" area on the marking sheet.
- Gouging **more** than .035 in. into parent or weld metal will result in a complete fracture rating of the strap
- Coupon must be presented to the markers immediately after gouging **prior to**
- **final grinding**
- Oxy-acetylene cutting process may be substituted in the event of equipment failure

Project 4: Double Position

Root (in Horizontal Position)

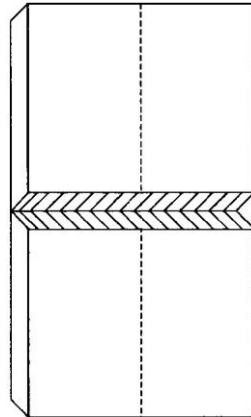

- 3/8 in. plate V-groove butt joint
- GTAW root in the horizontal position - fill rod diameter at the discretion of candidate
- Land and gap to be determined by candidate
- **NOTE:** coupons must be tacked **within the bevel only** using GTAW
- **NOTE:** It is required to request a marker to inspect your GTAW
- root pass **IN POSITION** once it has been completed before
- proceeding with the FCAW fill and cap.

Fill and Cap (in Vertical Position)

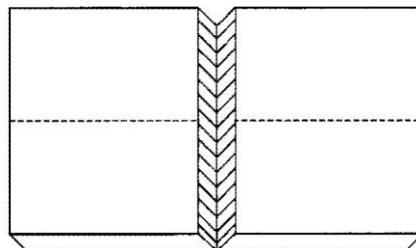

- FCAW fill and cap - vertical position using 0.035 flux-cored wire

Project 5: Flat Position

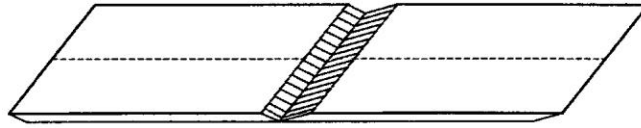

- 3/8 in. plate V-groove butt joint
- GMAW root - 0.035 wire
- GMAW fill and cap - 0.035 wire
- Land and gap to be determined by candidate
- Bridge tacks will be allowed **within the bevel only** using GMAW at the discretion of the candidate
- Run on/run off tabs or bridge tabs **tacked to the edges of the coupon only** will be allowed at the discretion of the candidate
- Weave or stringers may be used to fill and cap
- Candidate may select transfer mode

Oxy-fuel Cutting Tests - 3 Projects

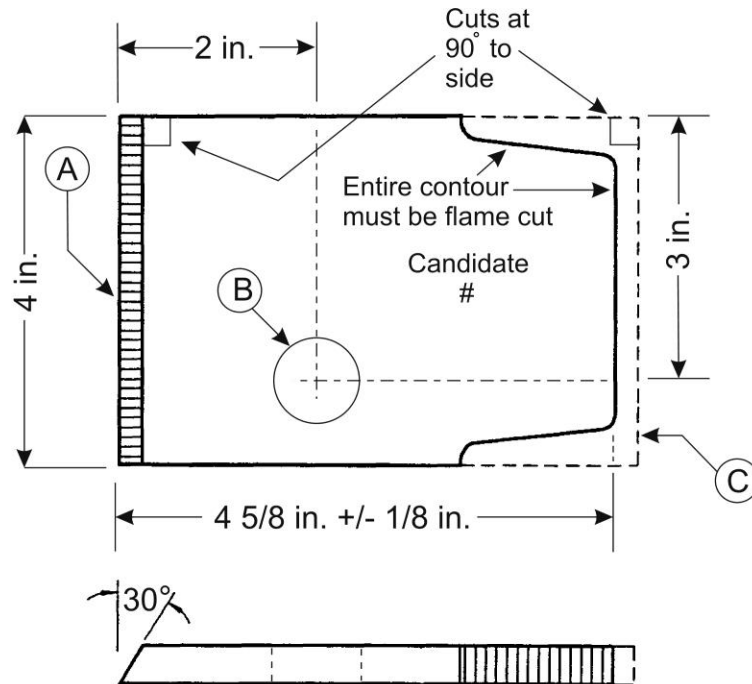

- Only one 4 in. x 5 in. x 3/8 in. Mild Steel plate cut at 90° both ends will be provided for this portion of the test.
No retest coupon will be allowed for this portion of the examination.
- Any measuring device may be used for marking layout lines. A 1 in. SCH 40 (1.315 in. OD) pipe and a section of 4 in. channel will be provided for marking the layout lines for the applicable projects of this test.
- **All cuts are to be made freehand.** Failure to do so will result in a deduction of 10 points for that portion of this test.
- **No grinding is permitted on any cut edges.** Knock off the slag and **lightly** file the edges to remove any burrs. Grinding of either cut edge will result in a deduction of 10 points for that portion of this test.
- **Overall length of the finished test plate must be within the tolerance stated in the above diagram.** Failure to do so will result in a deduction of 10 points from either Project A or Project C at the discretion of the markers.

Project A: Perform a 30° cut along the 4 in. end as shown in the diagram. Cut must be at 90° to the sides. The cut angle is allowed a **maximum** tolerance of +/- 3°.
Cut angle between +/- 4° to +/- 10° of 30° will result in a deduction of 2 points.
Cut angle in excess of +/- 10° of 30° will result in a deduction of 10 points.

Project B: Locate and perform a circular 90° cut to accept a 1 in. SCH 40 pipe (1.315 in. OD) as shown in the diagram. The fit of the pipe is allowed a **maximum** 3/32 in. clearance at any point.
Clearance between 3/32 in. and 1/4 in. will result in a deduction of 2 points.
Clearance of 1/4 in. or more will result in a deduction of 10 points.

Project C: Perform a coping cut to accept a 4 in. channel as shown in the diagram. Cut must be at 90° to the sides. The fit of the channel is allowed a maximum 3/32 in. clearance at any point.
Clearance between 3/32 in. and 1/4 in. will result in a deduction of 2 points.
Clearance of 1/4 in. or more will result in a deduction of 10 points

Test Factors and Maximum Deductions per Strap/Coupon SERIES 27/P/16	Welding Process Tests										Oxy-fuel Test		
	Vertical		Horizontal		Overhead		Double		Flat		Cope	30°	Circle
	R	F	R	F	R	F	R	F	R	F			
Incomplete Penetration - 3 points per 1/4 in. (10 maximum)													
Undercut - 1 point per 1/8 in. (Maximum 10 point deduction)													
Appearance - (including infractions regarding bevel face (Maximum 10 point deduction)													
Excess Penetration - (Maximum 4 point deduction)													
Bead Width - if over 3/4 in. except OH face - if over 1 in. (Maximum 2 point deduction)													
Pin Holes - 2 points each; 10 points if 3 or more													
Condition of Gouge - Maximum 5 point deduction per side of coupon. Deduct up to 5 points if gouge <i>not</i> within 1/16 in. of parent metal					left side	right side							
Partial Fracture - Deduct 1 point for each 1/16 in.													
Grinding/Gouging Straps for Thickness. Deduct up to 10 points if up to .035 in. removed.													
Strap Width - Deduct 2 points if less than 2 3/16 in. complete fracture rating if less than 2 5/16 in.													
Angle of cut: +/- 3° (Deduct 0) +/- 4° - 10° (Deduct 2 points) Exceed +/- 10° (Deduct 10 points)													
Excessive Heating - (Maximum 2 point deduction)													

Test Factors and Maximum Deductions per Strap/Coupon SERIES 27/P/16	Welding Process Tests										Oxy-fuel Test		
	Vertical		Horizontal		Overhead		Double		Flat		Cope	30°	Circle
	R	F	R	F	R	F	R	F	R	F			
Clearance of pipe or channel: 3/32 in. or less (Deduct 0 points) 1/8" to 7/32 in.(deduct 2 points) 1/4 in. or more (deduct 10 points)													
Position of 30° Cut (90° to sides) or location of hole on coupon up to 1/8 in. out = 2 point deduction 1/8 in. to 1/4 in. out = 5 point deduction over 1/4 in. out = 10 point deduction													
Correct length of cutting test coupon (4 5/8 in. +/- 1/8 in.). Deduct 10 points from either cope test or 30° test													
Grinding/Straight edge use on any flame-cut edge. Deduct 10 points.													
Strap = complete fracture if over .035 in. removed from parent/weld metal or grinding flame cut edges (mark using ★) (1 = retest; 2 = fail exam)													
Complete Fracture: (mark using ★) (1 = retest; 2 = fail exam)													
Maximum Credit per Strap or Coupon	10	10	10	10	10	10	10	10	10	10	10	10	10
Less Points Deducted													
Final Credit for Strap or Coupon													
Date:		Location:					Candidate Number:						
Fit-up Checked: <input type="radio"/>	GTAW root inspected: <input type="checkbox"/>				Single Strap Failure Position: V H O D F ROOT FACE								
SATCC FIELD CONSULTANT TO COMPLETE: TOTAL CREDIT: _____ X .77 = _____% PASS OR FAIL (circle one)													